

TOPWELL

Vertical Machining Centers



TOPWELL Machinery Co., Ltd



Topwell Machinery Co., Ltd. was established in 1986. Our factory is sitting in Chung Li city, Taiwan; near to the International Exchange Center ---- Taipei CKS air port. The floor space is 4,500 m². We are special in making Vertical, and Horizontal Machining Centers, and single spindle, multi-spindle engraver. With an experienced team of master technician, we focus on developing, and improving our machine. Also with an experienced assemblers, and high precision inspection instruments, our machine is precision scrapped, assembled, and tested to the latest ISO standard, and provide the reasonable price for our customers.



TW Series Machining Center With proven track records, and continual feedback from the most demanding customers, the TW series improves on many of the common weakness of many machining centers on the market today, including adding extended ribbings of the already extra wide column, and support base. Using Finite Element Analysis, and latest generation of CAD system to find the optimum compact design , coupled with properly aged high grade Mechanite castings, these machines not only allow for heavier cuts, but stands up to the rigors of everyday, high production use.

TW series Machining Center coupled with your choice of the most popular, fast speed CNC controllers, insures a high speed, precision workhorse that improve your work efficiency, uptime, and profiles.



- Using High-Grade Meehanite Casting Iron



- Machined by High-Precision Machining Center



- Experienced scrapping skill



- Well-trained assembler



High standard Inspection is Quality Insurance



Every machine has to be tested by Renishaw Laser, and Ball-Bar, and tuned to the best situation.

- The machine's dynamic accuracy, and repeatability is tested by the RENISHAW LASER system.
- The circularity is tested by the RENISHAW BALL-BAR system in order to ensure the profile.



Laser Linear Inspection

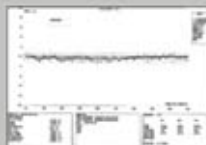

Laser Linear Report



Ball-Bar testing



Ball-Bar test Report

SPECIAL FEATURES

SPECIAL DESIGNED FUNDAMENTAL STRUCTURE

- Main casting are high grade GA-350 Meehanite castings, properly aged, and tempered to insure precision and stability.
- Full support box ways on all three axes allows for heavier cuts without distortion.
- Hardened and ground axes ways are line with Turcite-B for longevity, and smoothest movements.
- Hardened working table means less scratches, longer use, and easier setups

"A" type column structure design

TW serials heavy duty is using "A" type design on its column. The column's bottom is wider, and stronger so it can bear high speed movement on Z-axis.

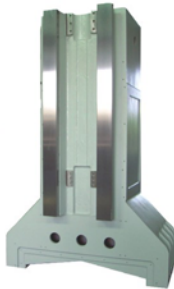

WIDER DESIGN FOR BASE'S SLIDE WAY

While most box ways of competitor's machine are only about 160mm wide, and thus easily deforms under heavy load or cut. Our ultra wide is 300 mm super wide box ways means the TW serials can handle even the heaviest, and toughest job with ease. The internal guide tapered gibs also insure less backlash, and Abe error, and thus affords a more precision machine.



Ultra-Wide Base Slide Way Design

WIDER WORK ENVELOP

Extra deep throat, and Y axis travel means extended versatility, and capability for machining bulky, and wide work pieces

| MODEL | X-Travel | Y-Travel | Z-trvel |
|-----------|----------|----------|---------|
| TW - 1650 | 1000 mm | 650 mm | 600 mm |
| TW - 1268 | 1200 mm | 680 mm | 610 mm |
| TW - 1480 | 1400 mm | 800 mm | 700 mm |
| TW - 1580 | 1500 mm | 800 mm | 700 mm |

Work Envelop for 3 axes

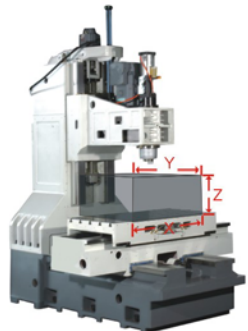

SPINDLE HEAT SINK RIB DESIGN

The head stock's design is based on the heat exchange theory, and turned into heat sink rib style. It can enhance the strength, and increase the heat radiation from the head stock.



EASY CLEAN-UP OIL TRAY DESIGN

The enlarged chip outlets, and high titling angle can be cleaned up easily, and keep the work environment clean.



EXTRA LARGE CHIP OUTLET

SUPER WIDE SAFETY DOOR DESIGN

The super wide safety door is using the enhanced glass to insure the worker's safety, besides, then the door is full opened, it can reach 1100 mm. The work pieces can be loaded, and unloaded very easily, and fast.

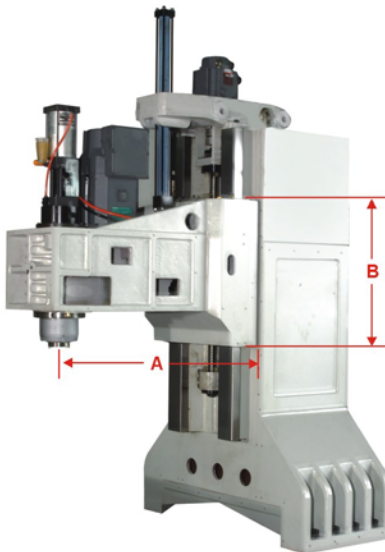

ENHANCED BOX-TYPE HEAD STOCK DESIGN

Optimum boxed shaped spindle housing with extra deep throat (A), and extended contact surface (B) means the most rigid, ideal design that resist distortion and allows for machining wider work pieces.

| MODEL | A (Throat) | B (Contact Surface) |
|-----------|------------|---------------------|
| TW - 1065 | 675 mm | 600 mm |
| TW - 1268 | 720 mm | 620 mm |
| TW - 1480 | 820 mm | 700 mm |
| TW - 1580 | 820 mm | 700 mm |

HI-SPEED HI-BIT CNC SYSTEM

HI-SPEED HI-BIT CNC CONTROL

Using the latest generation Mitsubishi Hi-speed Hi-precision M64S / M65S serials CNC control. The following CNC control are available also:
FANUC 0i / 18i
ANILAM 6300 Serials
SIEMENS 810 / 840 Serials
INTEK M350 / M450 Serials



MITSUBISHI M64 / M65 Serials

Hi-Speed Hi-Precision Function

The Mitsubishi M64S posses G5.1 Hi-Speed Hi-Precision function. It can look ahead 20 blocks of program when it makes the HSPH contouring.
It can smoothen the work pieces' surface, and reduce the working hours.



FANUC 0i / 18i Serials

Super Smooth Surface Function (Optional)

For Mitsubishi CNC control, it has the G5.1 P10000 HSHP MODE II to accomplish the smooth surface function (SSS). The function can calculate the small distance of the tool path, and modify the wrong path that created by CAM program. Besides, it can look ahead 180 blocks of program, and reduce the work time dramatically.



INTEK M350 / M450 Serials

Reliable Electro-Control

- All electrical control panels are in accord with the CE, and EMC standard, and passed the 96 hours continual test.
- All electrical control panel equipped with the heat exchanger in order to prevent the dust, reduce the temperature of control box and extend the life of all electrical components.

Heat Exchanger



NC Electro-Control Box



Easy Learn Operation Panel

- The easy learning operation panel provides the user friendly Human/ machine interface.
- The built-in operation console can be turned to 90 degrees. The user can operate machine from any view point. When it is turned back, it can save space, and looked good.



External MPG

The External MPG can make the user easier to set the work coordination, and tool setting.



RS232 DATA CABLE (Standard)

- The program can be sent by the RS-232 Data cable under 38,400 bpm baud rate, and execute the program under DNC mode.



Ethernet network / Network Hard Disk (Ethernet / ATAIC Card are Optional)

- The CAM program can be sent by the network by the Ethernet network card. The transaction speed is 10 Mb which is 250 times fast than the RS-232 transaction.
- The program is executed from the Network hard disk. It can eliminate the effect of outside interference. It can stabilize the machine, and reduce the working hour.
- Through the network system, one PC computer can connect to many machines. It can save money of PC, and share the program with others.

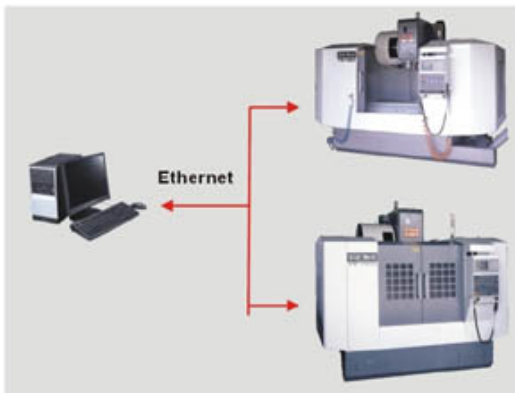

SPECIFICATION & ACCESSORIES

STANDARD ACCESSORIES

1. Meehanite Casting Iron (Meehanite : GA-350)
2. 10 · 15 · 20HP AC Spindle motor
3. Nitrogen Balanced System for Z-axis
4. BT-40# 6000RPM Spindle
5. Rigid Taping
6. AC Servo motors for X, Y, Z Axes
7. Telescope Guards for X, Y, Z Axes Slide Way
8. Hi-Precision C3 Grade Double nut Ball Screws
9. Auto Lubrication System
10. Coolant System with Coolant Tank
11. MPG
12. Beacon Light
13. Halogen Work Light
14. Heat Exchanger for Electro-Box
15. RS232 Data Cable
16. Full Enclosure Sheet Metals
17. M code Air Blow (M08)
18. Auto Power OFF system (M30)
19. Carousel type A.T.C.

Model : TW-1065

X Y Z axes travel : 1000 × 650 × 600 mm
Table size : 1200 × 600 mm
Spindle taper : BT#40 (CAT)
Spindle Hp : 10HP



Model : TW-1268

X Y Z axes travel : 1200 × 680 × 610 mm
Table size : 1500 × 600 mm
Spindle taper : BT#40 (CAT)
Spindle Hp : 15HP



OPTIONAL SPECIFICATION

- | | |
|---|---------------------------------------|
| 1. Arm type A.T.C. (24 tools) | 11. Chain type Chip Conveyor |
| 2. 8000/10,000/12,000RPM Hi-Speed Spindle | 12. Transformer (220V-380V-415V-440V) |
| 3. Spindle Chiller | 13. BT#50 Spindle 20HP 4500/6000rpm |
| 4. Coolant Through Spindle Device | 14. CAT#50 Spindle 20HP 4500/6000rpm |
| 5. Chip Conveyor | 15. CNC Control : |
| 6. Hi-Pressure Coolant Gun | MITSUBISHI 64S/65S |
| 7. Oil-Water Separation Device | FANUC 0i/18i |
| 8. Auto Tool Measurement | ANILAM 6300M |
| 9. 4th Axis Rotary Table | SIMENSE 810D/840D |
| 10. Auger type Chip Conveyor | FAGOR 8055MC |
| | INTEK M350/M450 |

Model : TW-1480

X Y Z axes travel : 1400 × 800 × 700 mm
 Table size : 1500 × 700 mm
 Spindle taper : BT#40 (CAT)
 Spindle Hp : 20HP



Model : TW-1580

X Y Z axes travel : 1500 × 800 × 700 mm
 Table size : 1600 × 700 mm
 Spindle taper : BT#40 (CAT)
 Spindle Hp : 20HP



STANDARD FEATURE

A HI-SPEED HI-PERFORM AC SPINDLE MOTOR

The spindle motor is high perform servo drive device with 64 bit high speed CNC control. The torque is well-perform under low speed, and high efficiency output. The noise, and vibration is low when high speed working.



TW-1065 (6000rpm)

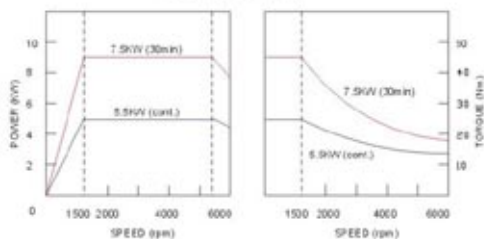

TW-1268 (6000rpm)

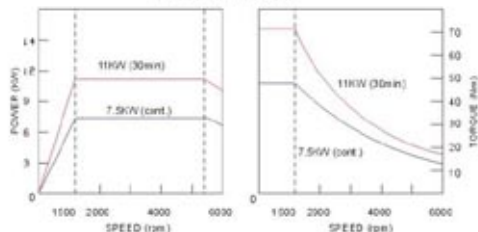

TW-1480 (4500rpm)

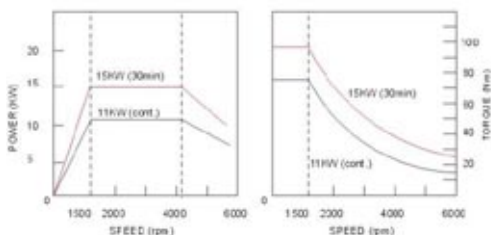

B SPECIAL FLOATING TOOL UNCLAMPING SYSTEM

Floating head power draw bar system means less chance of damage to spindle bearings during tool change.

C Auto Tool Change System (Carousel Type)

Reliable, and cost effective Bi-directional carousel type ATC for less demanding application.

D RIGID TAPING

The rigid tapping function can improve the performance of tapping procedure.

E HI-PRECISION HI-RIGIDITY SPINDLE DESIGN

- 6 pairs of P4 class oversized spindle bearings means increased rigidity, and accuracy.
- All spindles individually tested, and run in over 24 hours, and match with individual test certificates before installing on machine.
- All spindles dynamically balanced, and tested under full power.

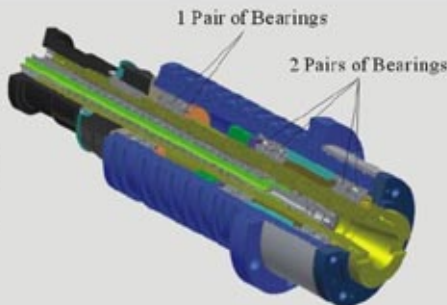

F NITROGEN BALANCED SYSTEM

The traditional counter-weight will cause the vibration, and shaking problem under high speed contouring. It will lead the scratch on work piece surface or the finish problem. The TW serial using the advanced Nitrogen balanced system. It can eliminate the vibration problem, and improve the surface of the work piece under high speed movement on Z-axis.

The comparison of Nitrogen Balanced System and conventional counter-weight

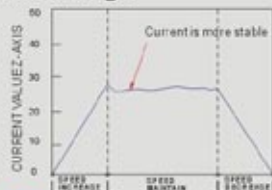

The conventional counter-weight will make the current unstable, and the finish will not be good when contouring.



The TW serials use Nitrogen Balanced System to prevent the vibration of Z-axis and make the finish better.

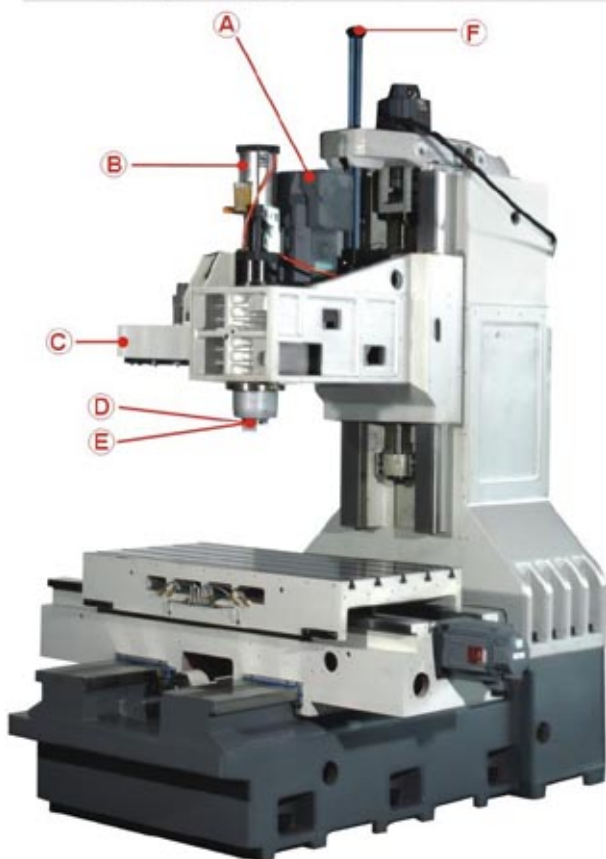
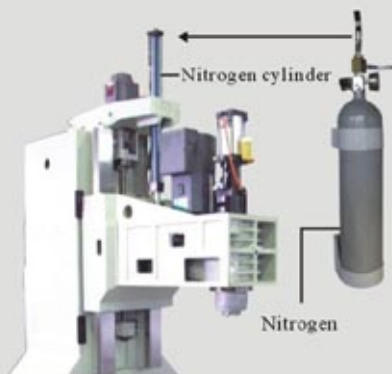

TELESCOPE GUARDS FOR 3 AXES

The metal telescope guards can totally protect the slide way, and avoid of the chip coming in to damage the slide way.



STANDARD FEATURES

1. AC SERVO MOTOR

3 axes are using the high response drivers. The motor can run full power no matter in low speed or high speed.



2. HIGH TORQUE COUPLING

The axis motor is connected to The precision ball screws by high Precision /High torque coupling.



3. P4 CLASS PRECISION BEARING

With P4 class precision bearings on each axis, and applying on suitable pre-load. The accuracy, and rigidity will be maintained.



4. C3 CLASS DOUBLE NUTS BALL SCREW

With high precision C3 Class double nuts ball screw, and applying on suitable pre-tension, the ball screws backlash can be reduced and the accuracy can be ensured.



5. AUTO LUBRICATION

Equipped with micro-computer control auto lubrication system, the slide way always keep wet, and extend the life of machine.



6. COOLANT SYSTEM

The TW series use the high Pressure coolant pump (3.5 bar) It can totally wipe out the chip on chip tray.

OPTIONAL FEATURES

TOPWELL

ARM TYPE A.T.C. (24 TOOLS)



It is using the random memory method, to memorize the tool.

The tool change time is only 2.8 Sec. (T to T)



AUTO TOOL MEASURE DEVICE



HIGH SPEED SPINDLE (8,000 / 10,000 / 12,000RPM, AND ABOVE)



SPINDLE CHILLER



COOLANT THRU SPINDLE



HIGH PRESSURE COOLANT GUN



CHIP FLUSHING SYSTEM



CHAIN TYPE CONVEYOR



AUGER TYPE CHIP CONVEYOR



OIL/COOLANT SEPARATION

4TH AXIS ROTARY TABLE

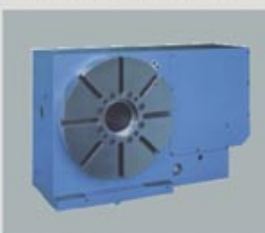

SPECIFICATIONS

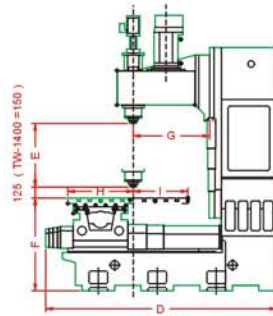
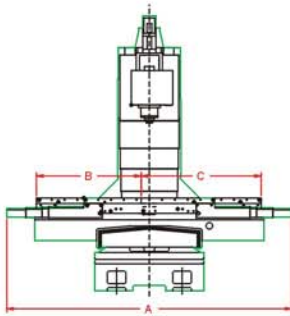

| MODEL | A | B | C | D | E | F | G | H | I |
|---------|------|------|------|------|-----|-----|-----|-----|-----|
| TW-1065 | 2862 | 1050 | 1200 | 2110 | 600 | 848 | 685 | 600 | 650 |
| TW-1268 | 3200 | 1200 | 1350 | 2110 | 610 | 848 | 720 | 600 | 680 |
| TW-1480 | 4020 | 1400 | 1500 | 2650 | 700 | 900 | 820 | 650 | 800 |

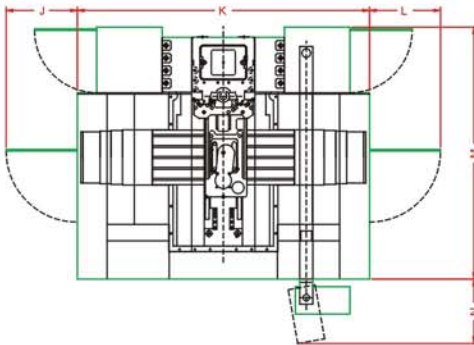

| MODEL | TA | TB | TC |
|---------|------|-----|-----|
| TW-1065 | 1200 | 600 | 125 |
| TW-1268 | 1350 | 600 | 125 |
| TW-1480 | 1500 | 650 | 135 |

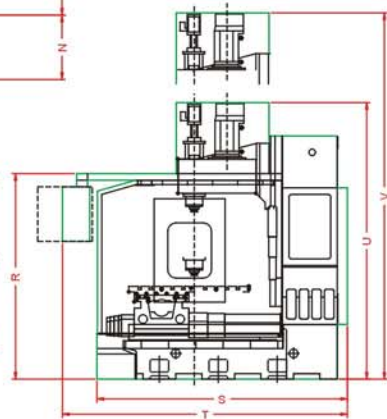
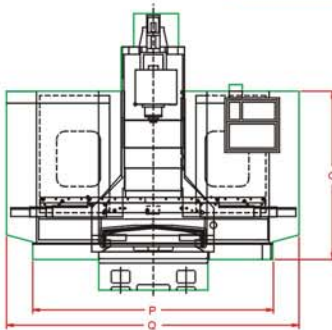

| MODEL | J | K | L | M | N | O | P | Q | R | S | T | U | V |
|---------|-----|------|-----|------|-----|------|------|------|------|------|------|------|------|
| TW-1065 | 650 | 2840 | 650 | 2300 | 600 | 2020 | 2200 | 2840 | 2020 | 2300 | 2600 | 2480 | 2700 |
| TW-1268 | 650 | 3400 | 650 | 2400 | 600 | 2020 | 2200 | 3400 | 2020 | 2400 | 2700 | 2480 | 2800 |
| TW-1480 | 650 | 4670 | 650 | 3300 | 800 | 2200 | 2200 | 4200 | 2120 | 3300 | 3600 | 2900 | 3200 |

SPECIFICATIONS OF MACHINE



| MODEL | TW-1065 | TW-1268 | TW-1480 | TW-1580 |
|----------------------------------|--|--------------------------|---------------------------|---------------------------|
| TRAVEL | | | | |
| X-AXIS (Longitudinal) | 1000 (40") | 1200 (48") | 1400 (55.1") | 1500 (59") |
| Y-AXIS (Cross) | 650 (25.5") | 680 (26.3") | 800 (31.5") | 800 (31.5") |
| Z-AXIS (Vertical) | 600 (23.6") | 610 (24") | 700 (27.5") | 700 (27.5") |
| Spindle nose to table surface | 125 - 725 (5" - 28.5") | 125 - 735 (5" - 28.9") | 150-850 (6"-33.5") | 150-850 (6"-33.5") |
| Spindle center to column surface | 685 (27") | 720 (28.3") | 820 (32.3") | 820 (32.3") |
| TABLE | | | | |
| Table dimension | 600X1000 (23.6"X47.2") | 600X1500 (23.6X59") | 700 X 1500 (27.5x59") | 700 X 1600 (26x62") |
| T-slots (Wide x No. x Pitch) | 18(0.70) x 5 x 80(3.15) | 18(0.70) x 5 x 100(3.94) | 18(0.70) x 5 x 125 (4.92) | 18(0.70) x 5 x 125 (4.92) |
| Table height from the floor | 860 (33.8") | | 880 (34.6") | 880 (34.6") |
| Table load capacity | 800kgs (1760lbs) | 1200kgs (2640lbs) | 2000kgs (4400lbs) | 2000kgs (4400lbs) |
| HEAD STOCK | | | | |
| Spindle nose (BT / CAT) | BT40 / BT50 | BT40 / BT50 | BT40 / BT50 | BT40 / BT50 |
| Spindle RPM (BT40) | 6000 / 8000 (opt.) | 6000 / 8000 (opt.) | 6000 / 8000 (opt.) | 6000 / 8000 (opt.) |
| Spindle RPM (BT50) | 4500 / 6000 (opt.) | 4500 / 6000 (opt.) | 4500 / 6000 (opt.) | 4500 / 6000 (opt.) |
| FEED RATE | | | | |
| Rapid travers for X, Y, Z | 15000 mm./min (591 ipm) | | | |
| Cutting feed for X, Y, Z | 1 - 5000mm./min (0.04. - 197ipm) | | | |
| MOTORS | | | | |
| Main motor BT40 (cont./30 min.) | 5.5Kw / 7.5Kw | 7.5Kw / 11Kw | 11Kw / 15 Kw | 11Kw / 15 Kw |
| Main motor BT50 (cont./30 min) | 7.5Kw / 11Kw | 11Kw / 15Kw | 15Kw / 18Kw | 15Kw / 18Kw |
| AC servo motor for each axis | 2Kw-14NM / 3.5Kw-22NM (opt.) | | 3.5Kw-22NM | 3.5Kw-22NM |
| Coolant system | 580W | | | |
| Lubrication system | 25W | | | |
| Spindle chiller system | 850W for spindle 8000RPM | | | |
| AUTO TOOL CHANGER | | | | |
| Magazine for Carousel type | 16 (Standard) / 20 (Optional) | | | |
| Magazine for arm type | 24 (Standard) / 32 (Optional) | | | |
| Max. tool diameter | BT40: 76 / 127 (3"/5") BT50: 125 / 180 (5"/7") | | | |
| Max. tool length | BT40: 300 (11.8") BT50: 350 (13.8") | | | |
| Max. tool weight | BT40: 7 kgs (15lbs) BT50: 15 kgs (33lbs) | | | |
| ACCURACY | | | | |
| Positioning | ±0.0030mm / ±0.0012" | | | |
| Repeatability | ±0.0025mm / ±0.001" | | | |
| GENERAL INFORMATION | | | | |
| Air pressure | 5Kg / cm ² over | | | |
| Machine weight | 5800kgs (12760lbs) | 6500 (14300lbs) | 12000 (26400lbs) | 12000 (26400lbs) |
| Floor space (L x W x H) | 3200x2800x2700 | 3200x3300x2800 | 3900x4200x3200 | 3900x4200x3200 |
| | 126"x110"x106" | 126"x130"x110" | 154"x165"x126" | 154"x165"x126" |
| CNC Controller | MITSUBISHI Melder 64S / 65S - FANUC 0 _i / 18M - ANILAM 6300 - SIEMENS 810 / 840 - FAGOR 8040-MC / 8055-MCD - INTEK M350 / M450 - SELCA 4045DH | | | |

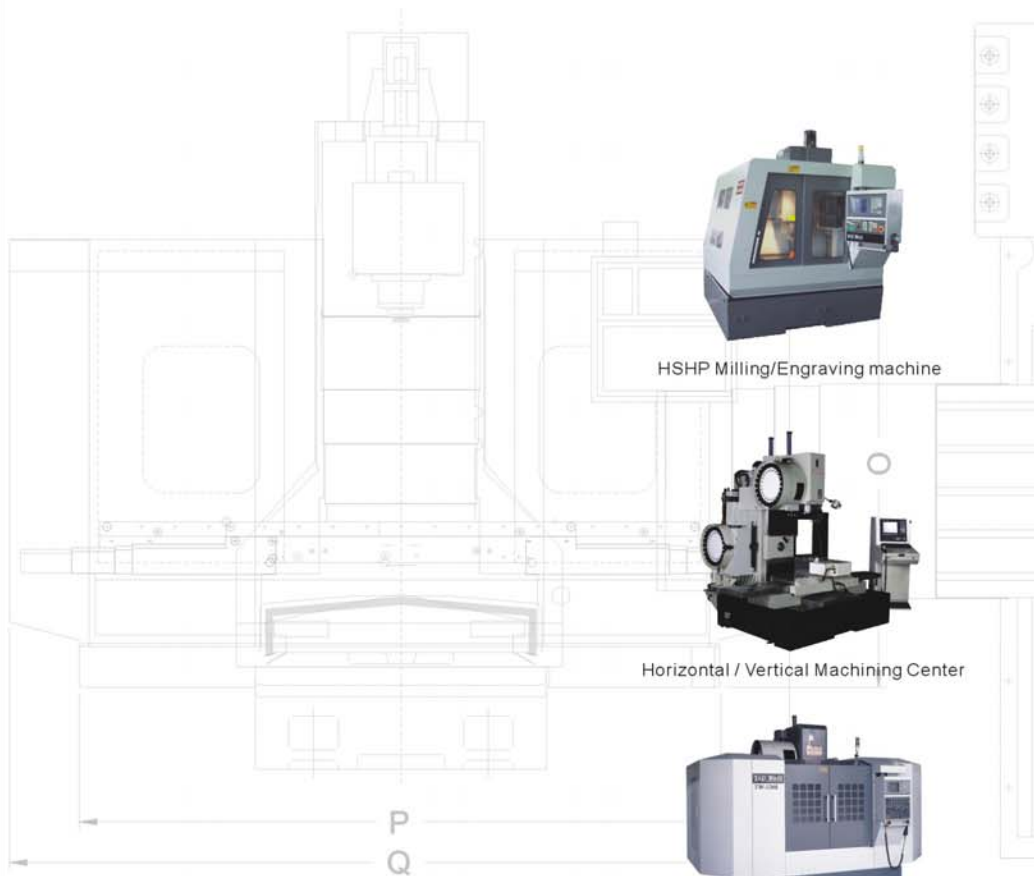

HSHP Milling/Engraving machine



Horizontal / Vertical Machining Center



Vertical Machining Center



TOPWELL Machinery Co., Ltd

ADD : 160, Shan Shiah, Shan Tung Li, Chung Li City,
Tao Yuan Hsien, Taiwan

E-mail : twmc@ms18.hinet.net TEL : 886-3498-6182
<http://www.topwell.com.tw> FAX : 886-3498-6003

Specification is subjected to change without notice2004.9



Heavy-duty Machining Center

WE ALSO PROVIDE YOU....